

VENUS

Versatile Folding and Stacking System for Flat & Fitted Sheets



The VENUS system automatically folds and stacks both flat and fitted sheets, making a standard fold, Book-Fold, and Brintech's exclusive **One-Layer Fold**.

Using Brintech's innovative folding method, the VENUS is the only system of its kind that can insert the cardboard into the first or second layer of the product showing only one layer of the border on the front of the folded sheet.

Products Folded	<ul style="list-style-type: none"> • Flat Sheets • Fitted Sheets
Unfolded Product Size	120" x 120" Max.
Final Folded Size	6" x 9" to 14" x 14"
Folding Capabilities	<ul style="list-style-type: none"> • Standard Fold • Book-Fold • One-Layer Fold

- ▶ **Accurate and Consistent Folding**
- ▶ **Attractive Presentation**
- ▶ **High Versatility**
- ▶ **Quick Folding Program Changeability**

VENUS

The Venus system automatically folds both flat and fitted sheets making a standard fold, a **Book-Fold**, and Brintech's exclusive **One-Layer Fold**. The Venus accommodates various material types including *poly/cotton, sateen, flannel, sheets with lacing, piping, and sheets with ruffles*. Folded sheets are stacked in two troughs which hold up to 200 folded sheets each.

Folding and Stacking Method

The Venus will fold flat sheets with 5 lateral folds and 5 crossfolds.

- The 1st crossfold is accomplished with an air blast assistance between pinch rolls.
- Cardboard Inserter can insert a cardboard into the sheet before the 1st lateral fold is made.
- The 1st, 2nd, 3rd, 4th and 5th lateral folds are made by mechanical blades over adjustable skis.
- The 2nd crossfold is accomplished by a linear folding arm.
- The 3rd and 4th crossfolds are made by mechanical folding arms (Swing Arm Unit).
- Brintech's **Pressing Unit** presses down each folded item after the 4th crossfold to enhance package quality (optional).
- The 5th crossfold is accomplished by Brintech's advanced **Fold-N-Stack** unit, which uses mechanical arms with knife assistance in order to fold the sheet.
- As the last fold is completed, the **Fold-N-Stack** stacks the sheet vertically on one of two troughs. 1st quality items are stacked on the 1st trough, and 2nd quality items are stacked on the 2nd.

Control System

The Venus is controlled by a high-speed computer (PLC) with up to 70 folding programs. Operator interface is a 10.4" color active matrix touch screen, which displays trouble-shooting messages and allows for output tests.

The PLC can be linked to an office computer with Brintech's **Machine-to-Office Computer Link**, which enables customers to collect data and monitor the status of the system in real time via web page on their office computer. This link also enables Brintech's support staff to connect to the machine's computer via Internet and to perform diagnostic tests, trouble-shooting, and software upgrades without being physically present at the customers' plant.

Features & Benefits

- A cardboard is inserted into the first or second layer of the sheet showing only one layer of the border on the front of the folded sheet. This creates a very attractive package and keeps any cardboard edges from showing on the outside of the sheet.
- Cardboard Inserter will accommodate various cardboard types, including corrugated.
- All drive motors are controlled by **frequency inverters**, which increase folding accuracy, eliminate the use of brake motors, and minimize the mechanical shock and stress to the drive systems. The use of these inverters also reduces maintenance, downtime, and prolongs the life of the system.
- All lateral fold skis will automatically adjust to proper width according to the folding program selected by the operator.
- 2nd and 3rd quality sorting is made by the operator using push-buttons on the inlet conveyor.
- The Venus is equipped with indicator lights and a sound alarm: Production Pacer, Cardboard Unit Monitor, Machine Jam Alert, and Stacker Troughs Full Signal.

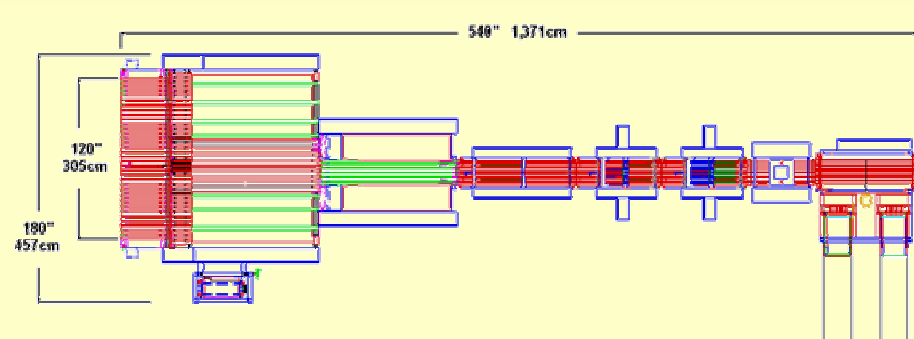

Specifications are subject to change without notice.

Specifications

Minimum Sheet Size
Twin

Maximum Sheet Size
King, Cal. King

Minimum Folded Size
6" x 9" (15cm x 23cm)

Maximum Folded Size
14" x 14" (35cm x 35cm)

Folding Speed
Up to 600 sheets per hour

Air Connection
1" NPT ~ 12cfm

Electric Connection
220VAC +5% 3Phase
60Hz 8KW (380V 50Hz)