

JUPITER

Pillow Sham Folding System



The Jupiter system accurately folds pillow shams of various material types and sizes.

A cardboard can be inserted into the pillow sham, and folded shams are stacked to a desired stack count. The Jupiter folds **900** pillow shams per hour, separating 1st and 2nd quality shams. The Jupiter can be linked to an office computer for monitoring performance and data collection.

JUPITER

The Jupiter system automatically folds and stacks pillow shams of various material types and sizes including padded, quilted, and corded pillow shams. A cardboard can be inserted if desired, and folded shams are stacked. The Jupiter can be connected to a flanging system for automatic feeding, or remain free standing for manual feeding.

Folding and Stacking Method

The Jupiter accurately folds pillow shams with 4 lateral folds and 2 crossfolds.

- The 1st, 2nd, 3rd, and 4th lateral folds are made with mechanical blades over adjustable skis.
- The 1st and 2nd crossfolds are accomplished by reverse conveyors and blade assistance.
- Cardboard Inserter can insert a cardboard into the pillow sham at the 1st crossfold (optional).
- Folded pillow shams are stacked by a retracting plate stacker. Once a stack contains the preset number of pillow shams, it is indexed forward on a conveyor.

Control System

The Jupiter is controlled by a high-speed computer (PLC) with up to 70 folding programs. Operator interface is a 2-line display, which shows trouble-shooting messages and allows for output tests.

The PLC can be linked to an office computer with Brintech's **Machine-to-Office Computer Link**, which enables the customer to collect data and monitor the status of the system in real time via web page on their office computer. This link also enables Brintech's support staff to connect to the machine's computer via internet and to perform diagnostic tests, trouble-shooting, and software upgrades without being physically present at the customer's plant.

Features & Benefits

- All lateral fold skis automatically adjust to the proper width according to the folding program selected by the operator.
- 2nd and 3rd quality sorting is made by the operator using push-buttons on the inlet conveyor.
- The machine is equipped with indicator lights and a sound alarm: Production Pacer, Cardboard Unit Monitor, and Machine Jam Alert.
- All drive motors are controlled by **frequency inverters**, which increase folding accuracy, eliminate the use of brake motors, and minimize the mechanical shock and stress to the drive systems. The use of these inverters also reduces maintenance, downtime, and prolongs the life of the system.

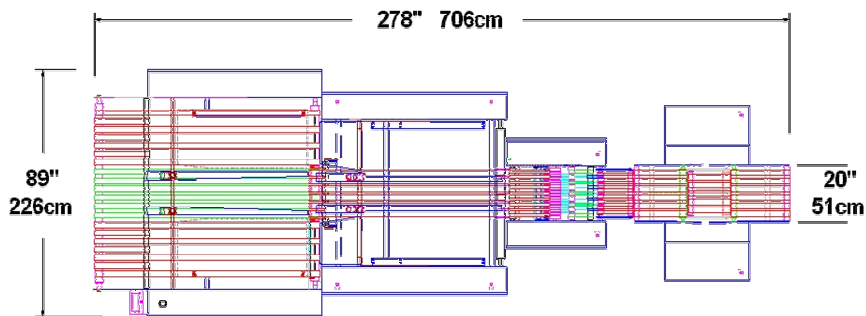

Specifications

Minimum Pillow Sham Size

Standard

Maximum Pillow Sham Size

King

Minimum Folded Size

5" x 8.5" (12.50cm x 21.50cm)

Maximum Folded Size

12" x 14" (30.50cm x 35cm)

Folding Speed

Up to 900 pillow shams per hour

Air Connection

1" NPT ~ 8cfm

Electric Connection

220VAC +/-5% 3Phase
60Hz 5KW (380V 50Hz)

Specifications are subject to change without notice.